

RH-18/36/38 Schematic Diagrams

Table of Contents	Page
BB/RF connection block diagram v.0.0 ed.79	3
Mjölner IC v.0.0 ed. 229	4
Power amplifier diagram v. 0.0 ed.135	5
Baseband block diagram v. 0.0 ed. 343	6
Audio schematic diagram v. 1.3 ed.48	7
Keyboard diagram v. 1.3 ed.52	8
Flash memory diagram v. 2.0 ed.36	9
Discrete capacitors for memory without VFlash1 v. 1.3 ed.11	10
Discrete power v.1.3 ed.120	11
Light filtering diagram, v.2. 0 RH*	12
Old power discrete capacitors, v. 0.0 ed. 9	13
Power resistor v. 0.0 ed.4	13
RF/BB connection, v. 1.3 ed.28	14
SIM v. 1.3 ed. 32	15
System connector v. 1.3 ed.51	16
UPP 8M diagram, v. 2.0 ed. 107	17
Discrete decoupling capacitors for UPP v., 1.3 ed.10	18
Audio and Global Ground v. 0.0 RH*	18
Component layout 1AW_07a, top side	19
Component layout 1AW_07a, bottom side	20
Test Points, Baseband	21

BB/RF connection block diagram v.0.0 ed.79

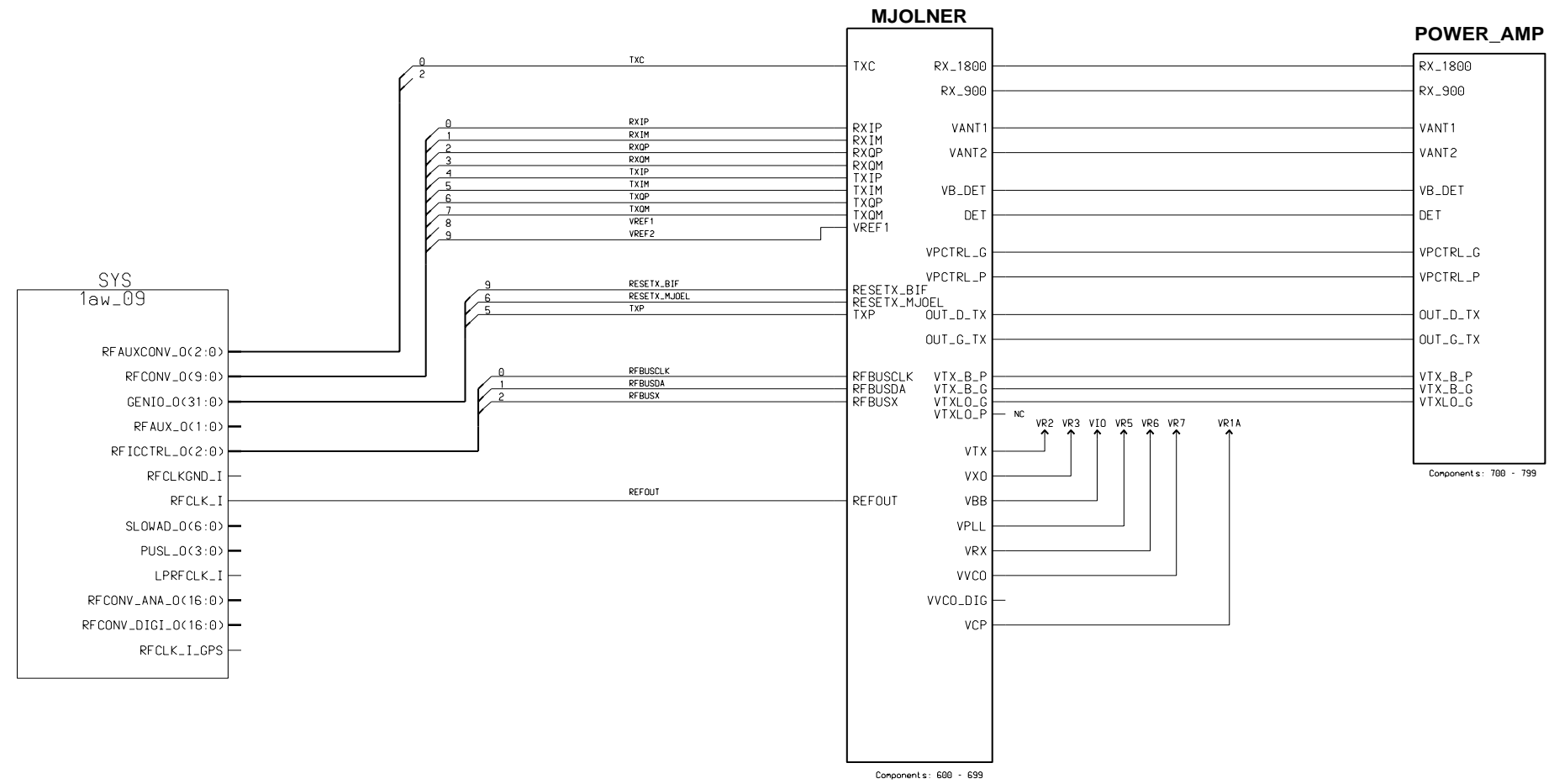

Mjølner IC v.0.0 ed. 229

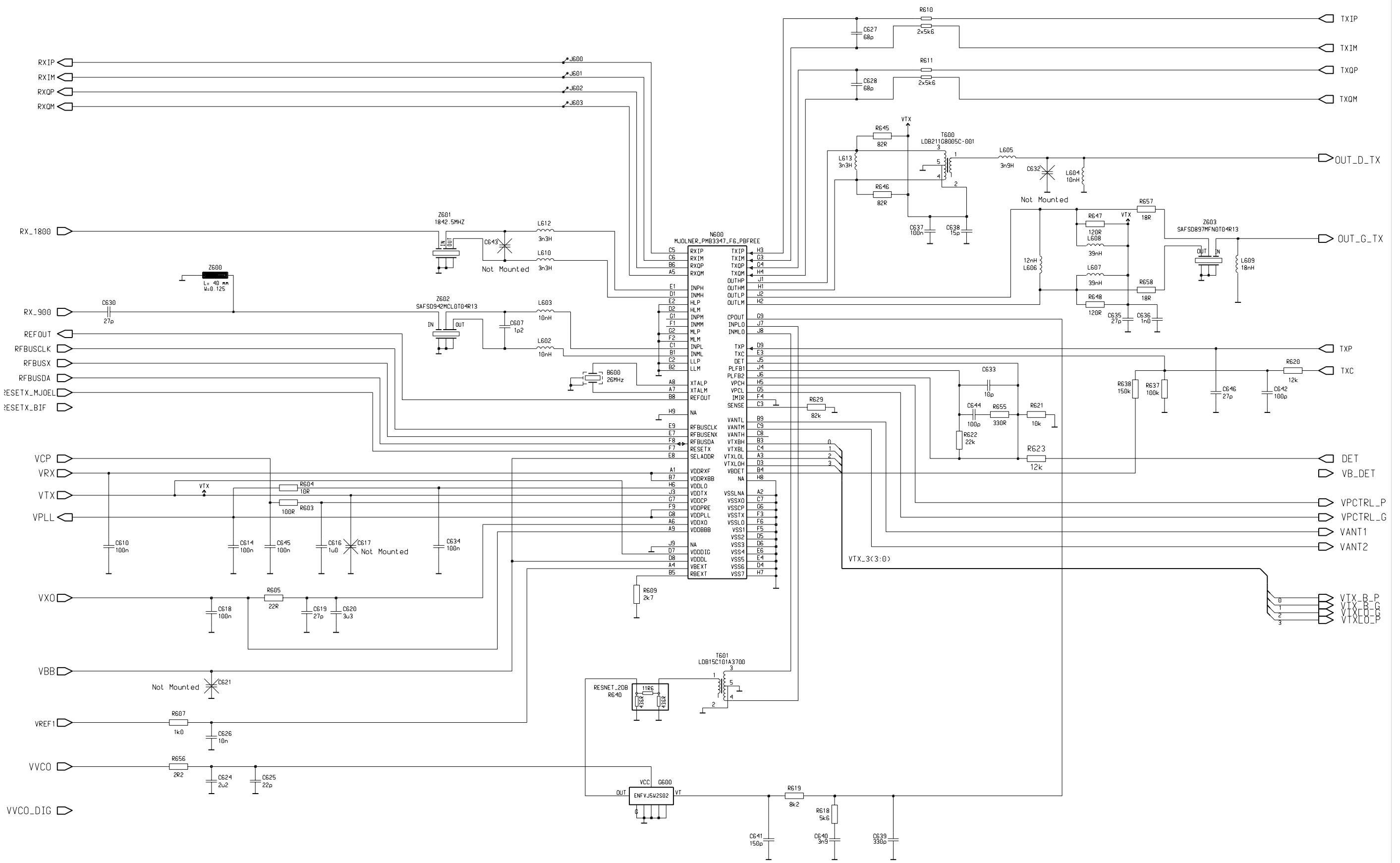

Power amplifier diagram v. 0.0 ed.135

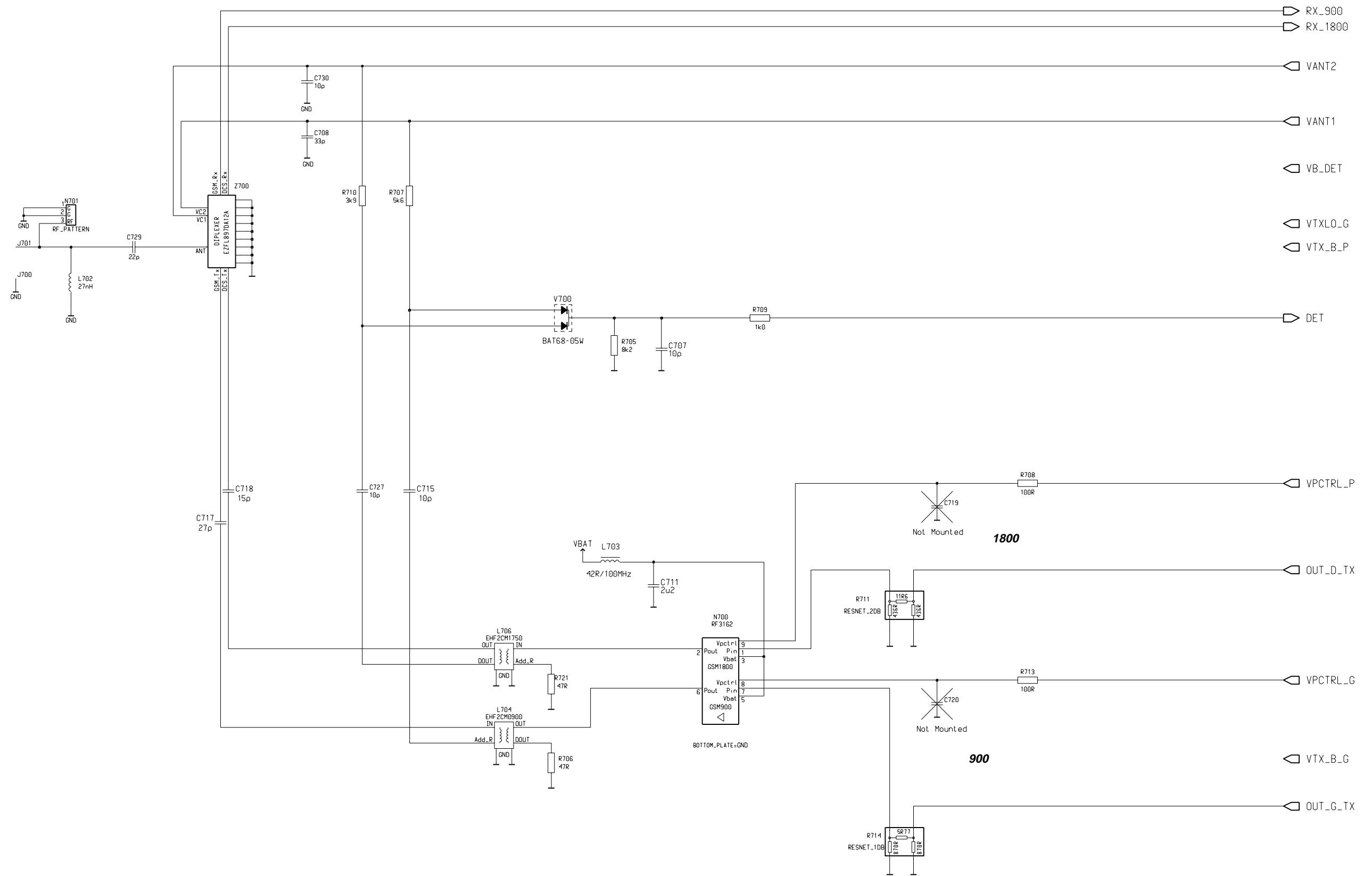

Baseband block diagram v. 0.0 ed. 343

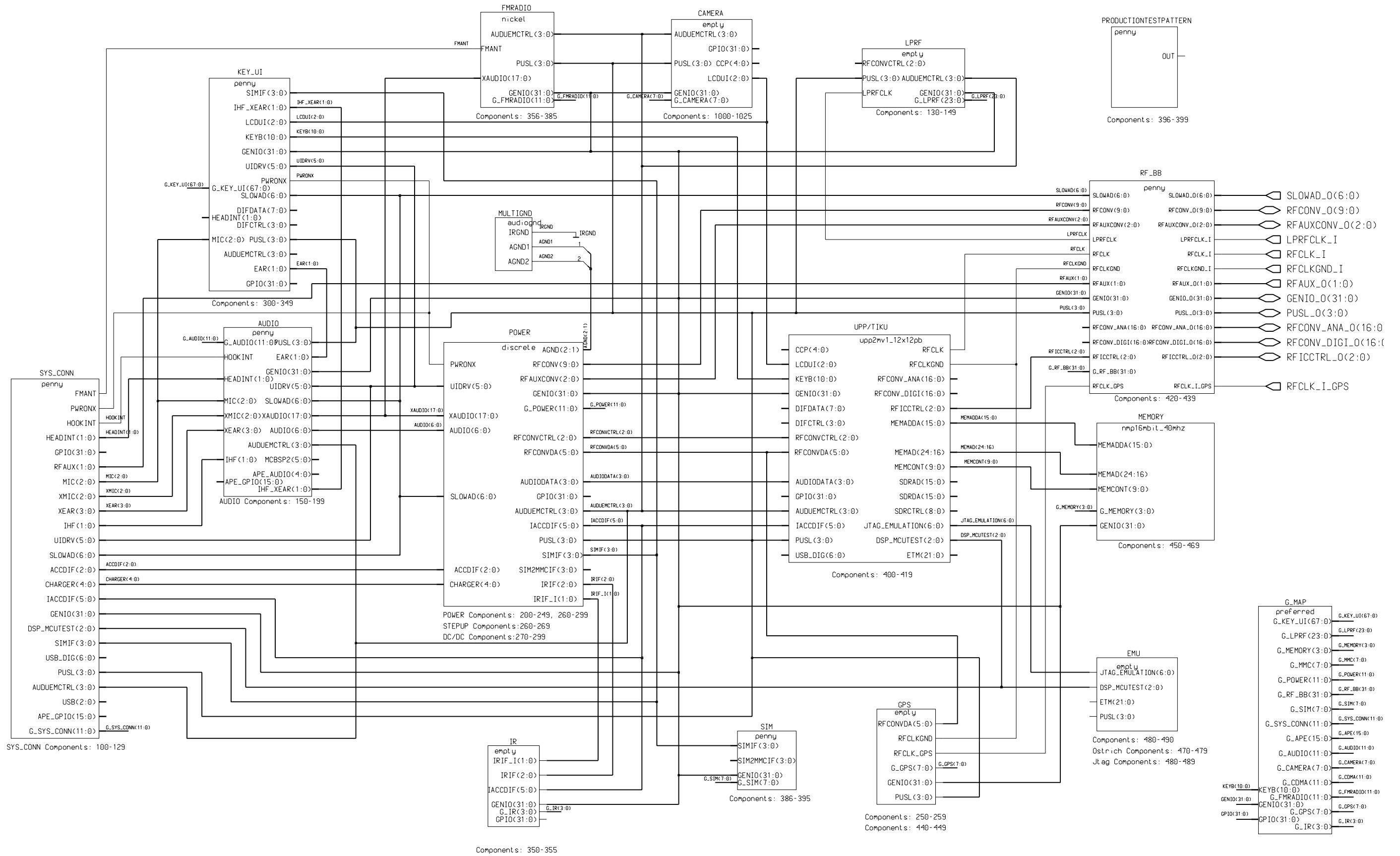

Audio schematic diagram v. 1.3 ed.48

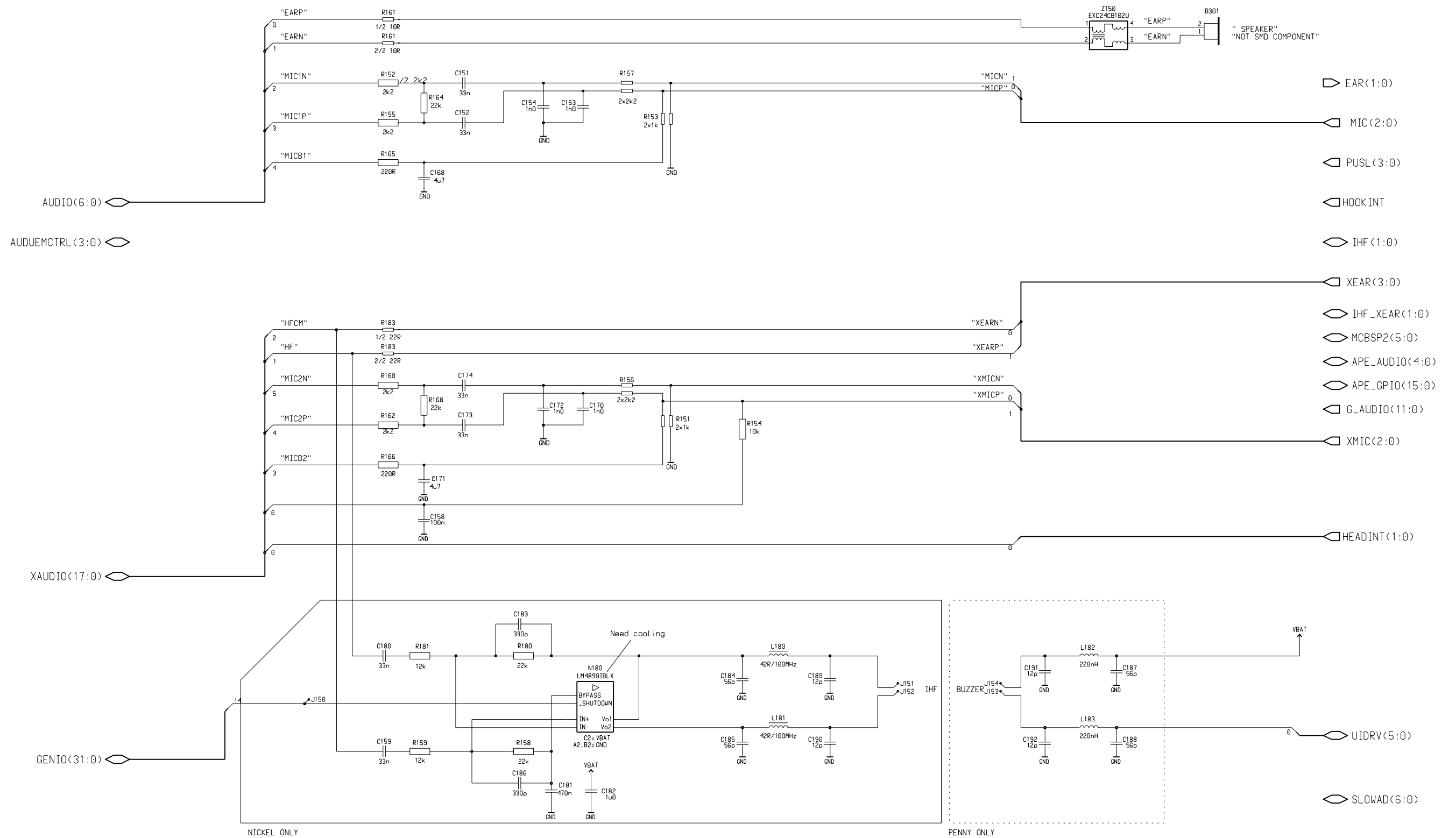

Keyboard diagram v. 1.3 ed.52

- AUDUEMCTRL<3:0>
- DIFDATA<7:0>
- DIFCTRL<3:0>
- MIC<2:0>
- PUSL<3:0>
- GPIO<31:0>
- G_KEY_UI<67:0>
- HEADINT<1:0>
- SIMIF<3:0>
- IHF_XEAR<1:0>

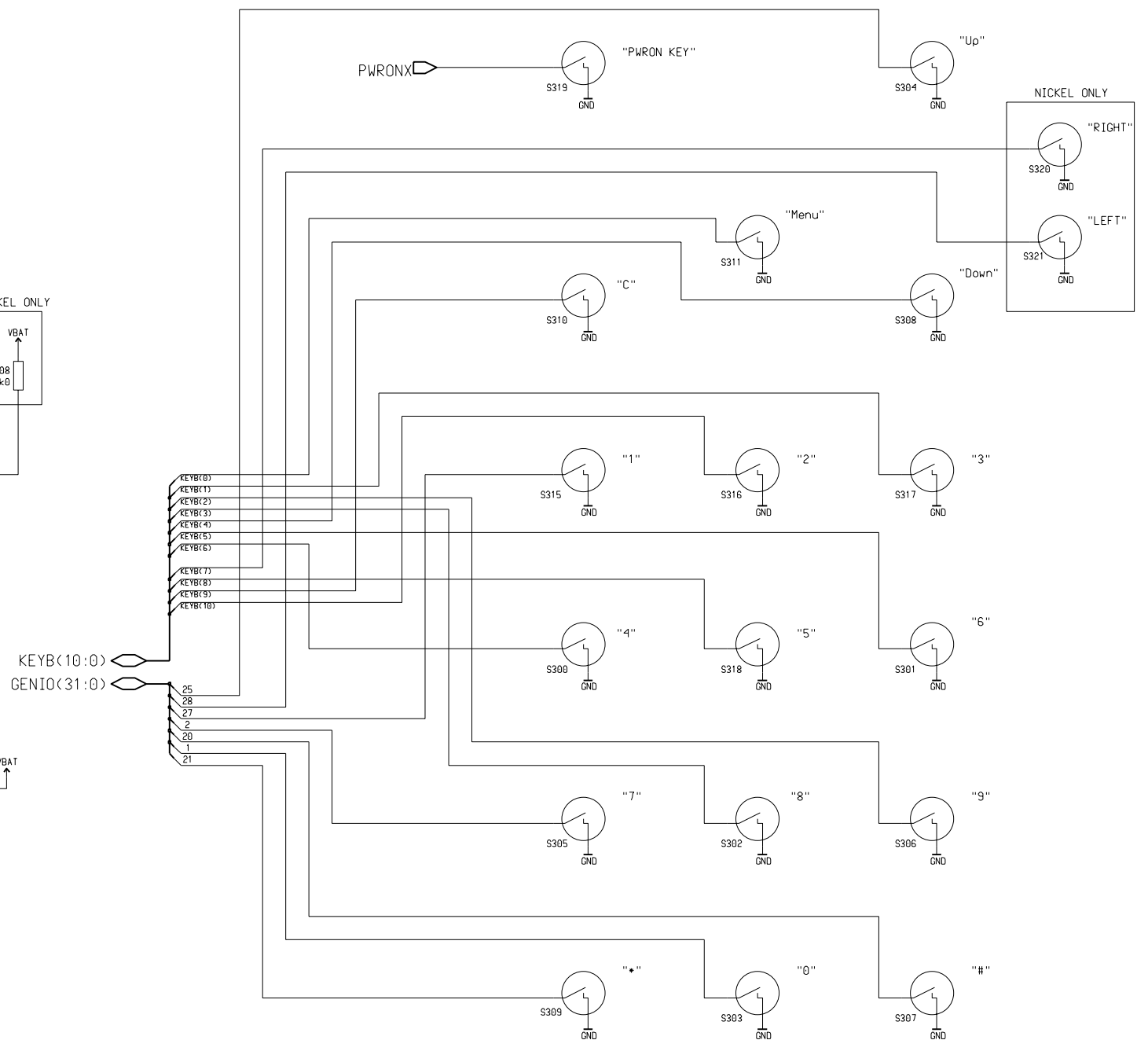
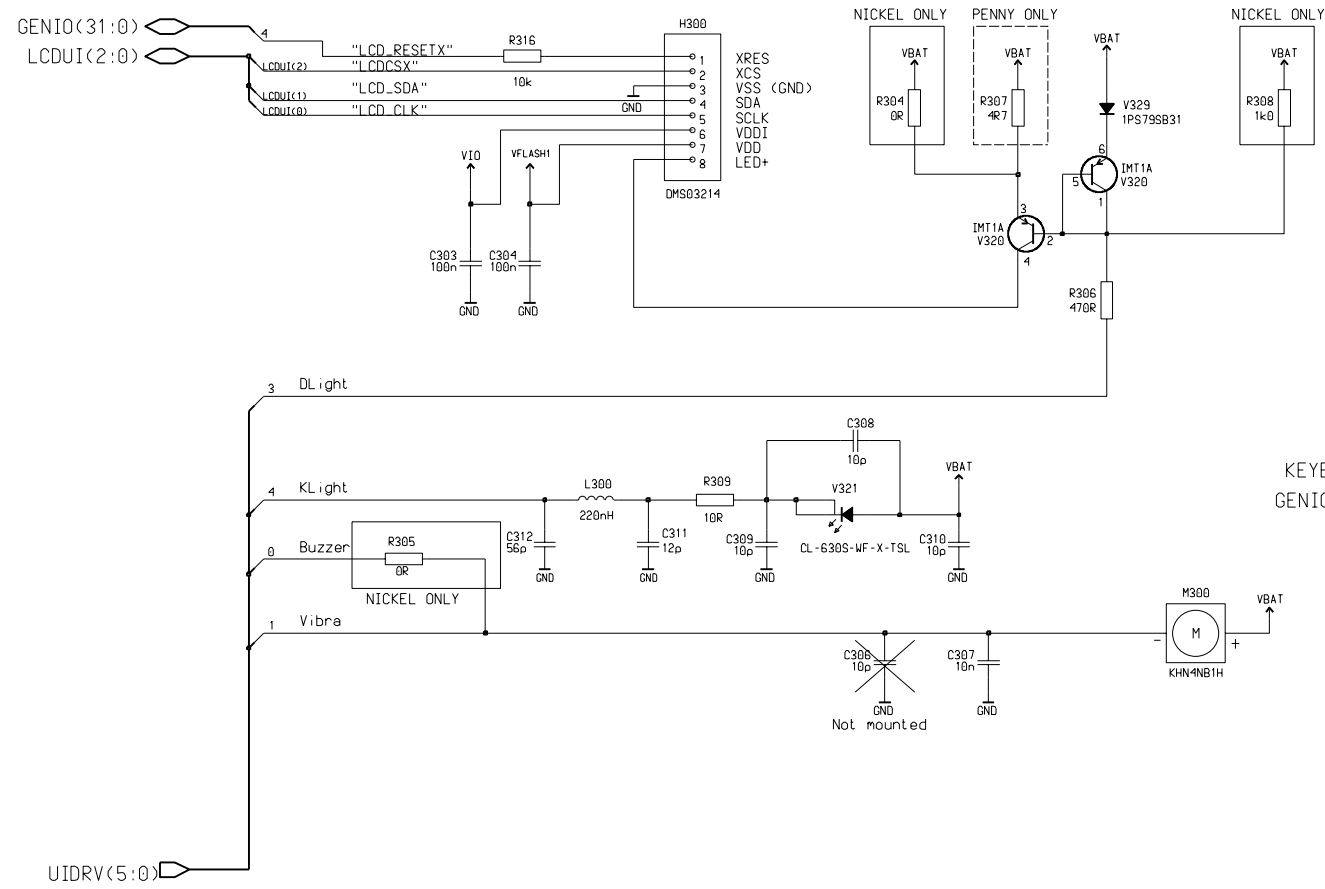

- SLOWAD<6:0>
- EAR<1:0>

Flash memory diagram v. 2.0 ed.36

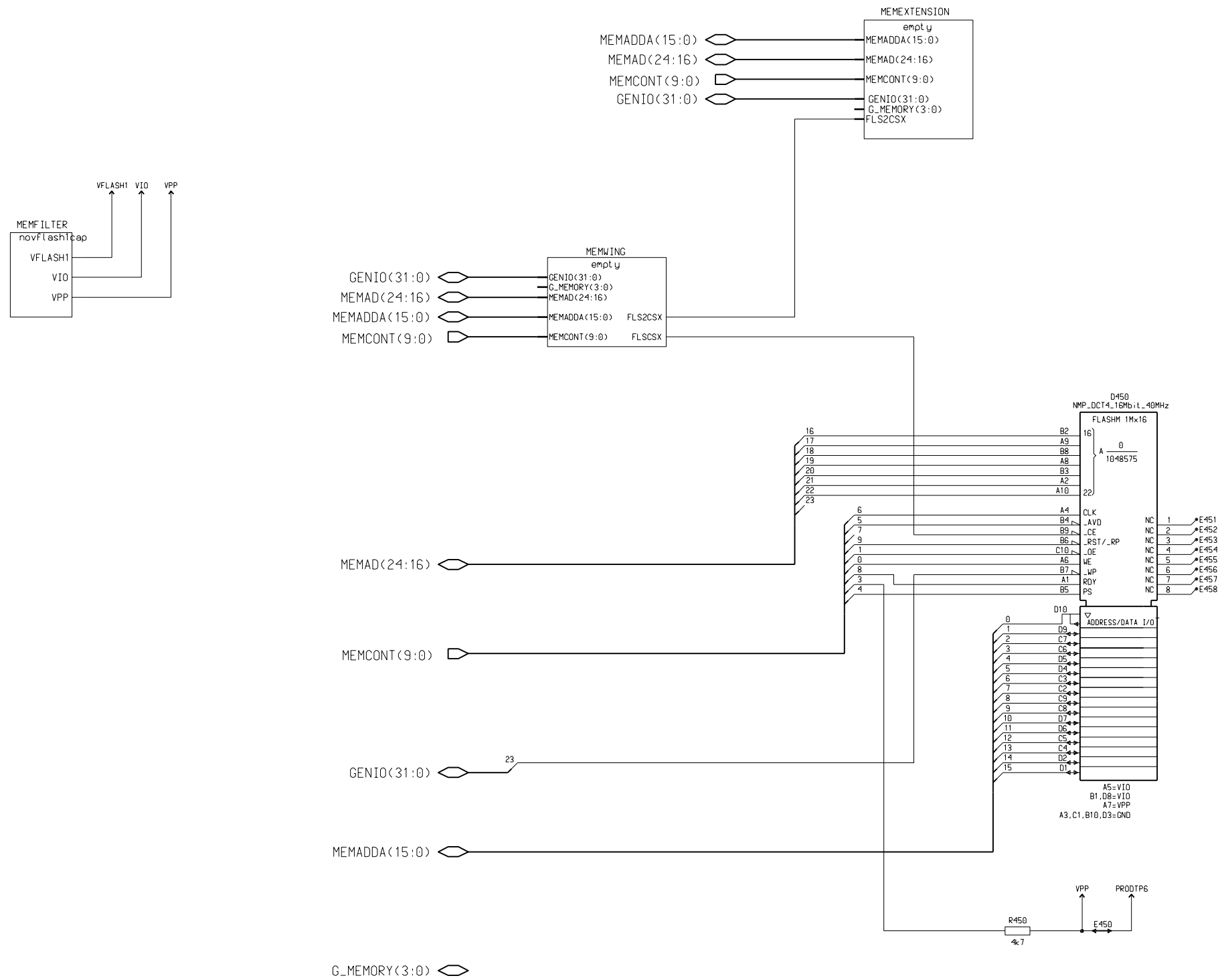

Discrete capacitors for memory without VFlash1 v. 1.3 ed.11

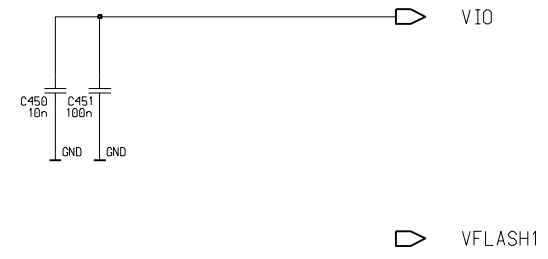

Discrete power v.1.3 ed.120

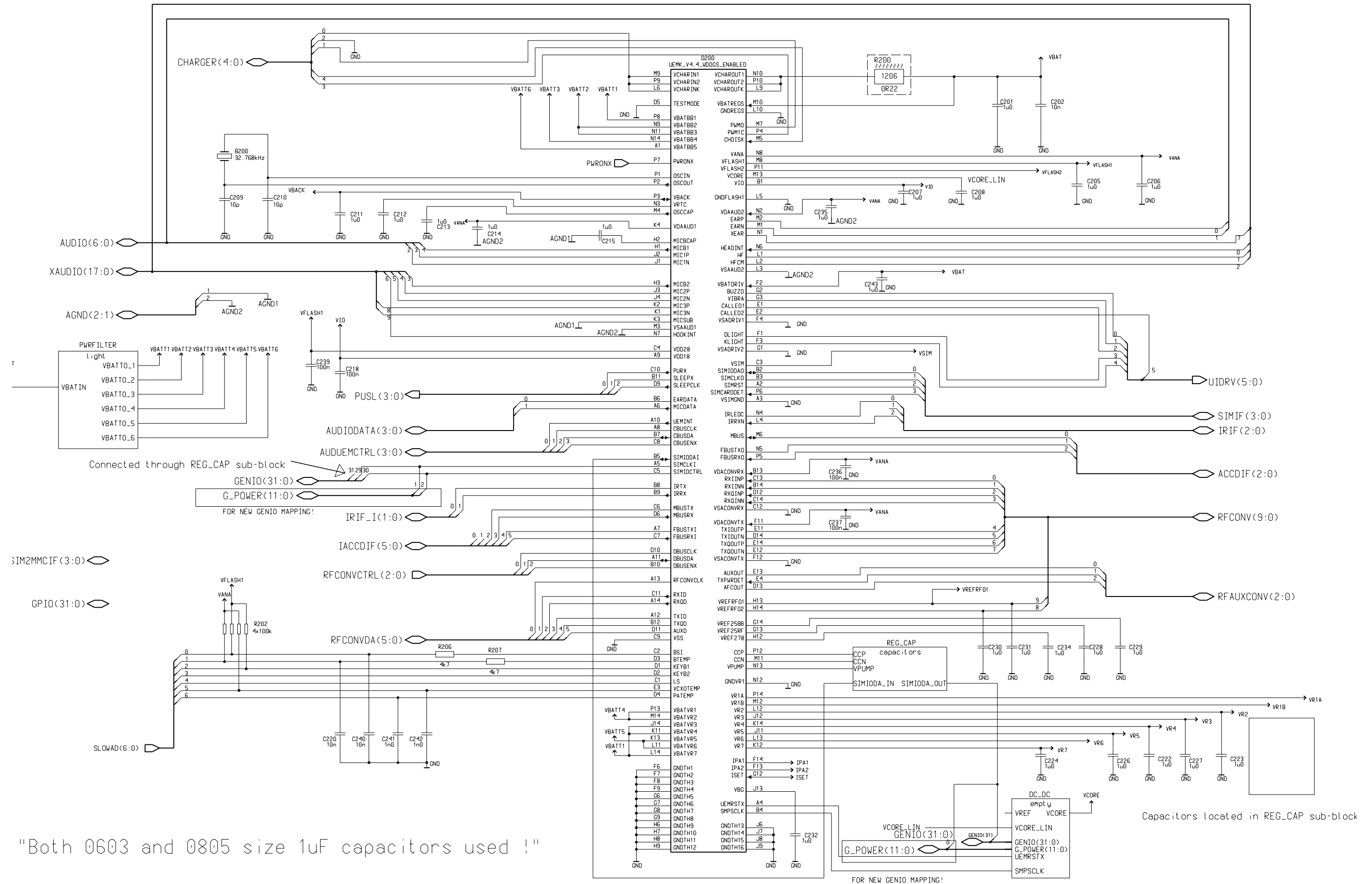

"Both 0603 and 0805 size 1uF capacitors used !"

Used refs in REG_CAP: C238, C200, C219, C233, C221 and R205

Capacitors located in REG_CAP sub-block

Light filtering diagram, v.2. 0 RH*

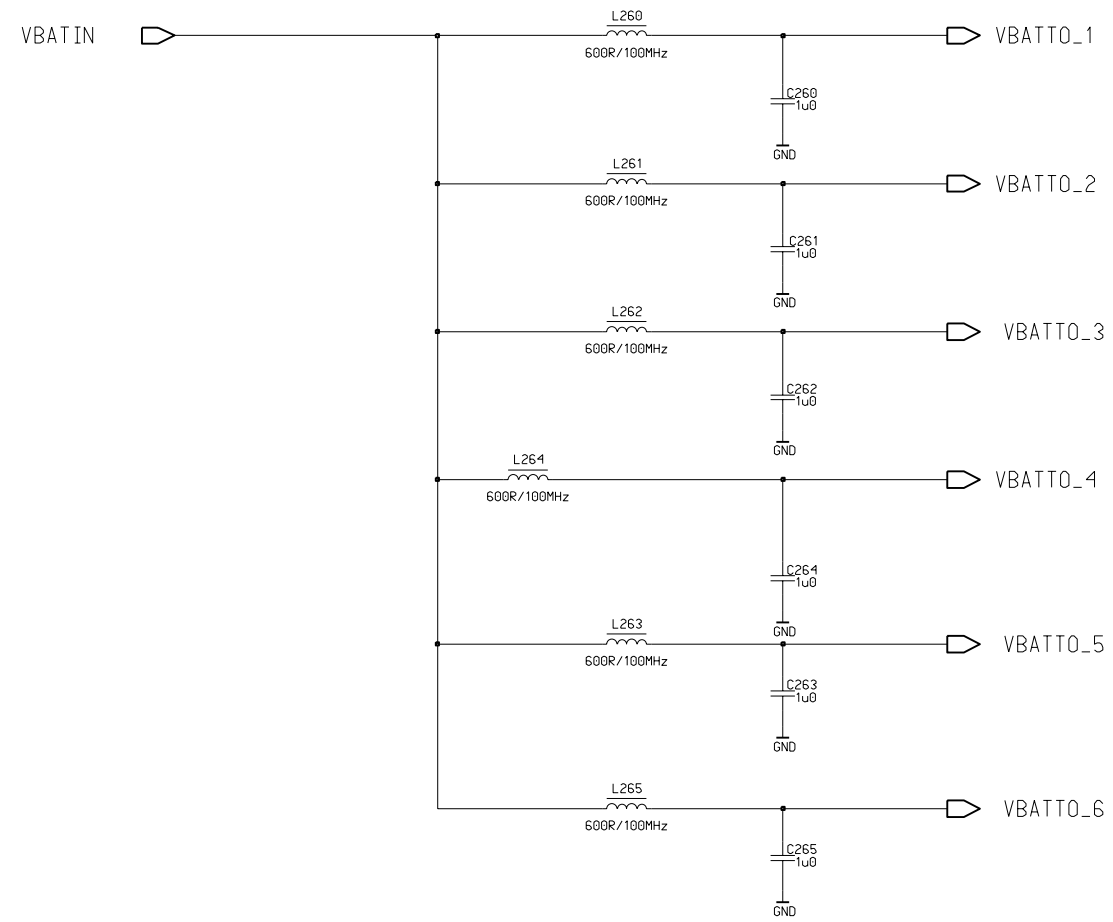

Old power discrete capacitors, v. 0.0 ed. 9

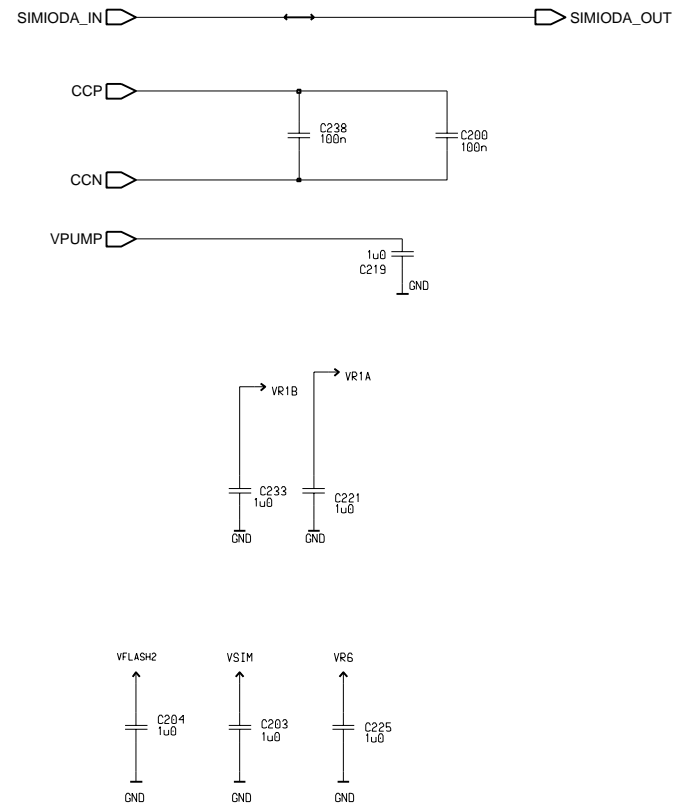

Power resistor v. 0.0 ed.4

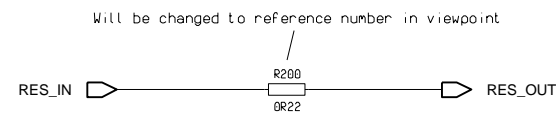

RF/BB connection, v. 1.3 ed.28

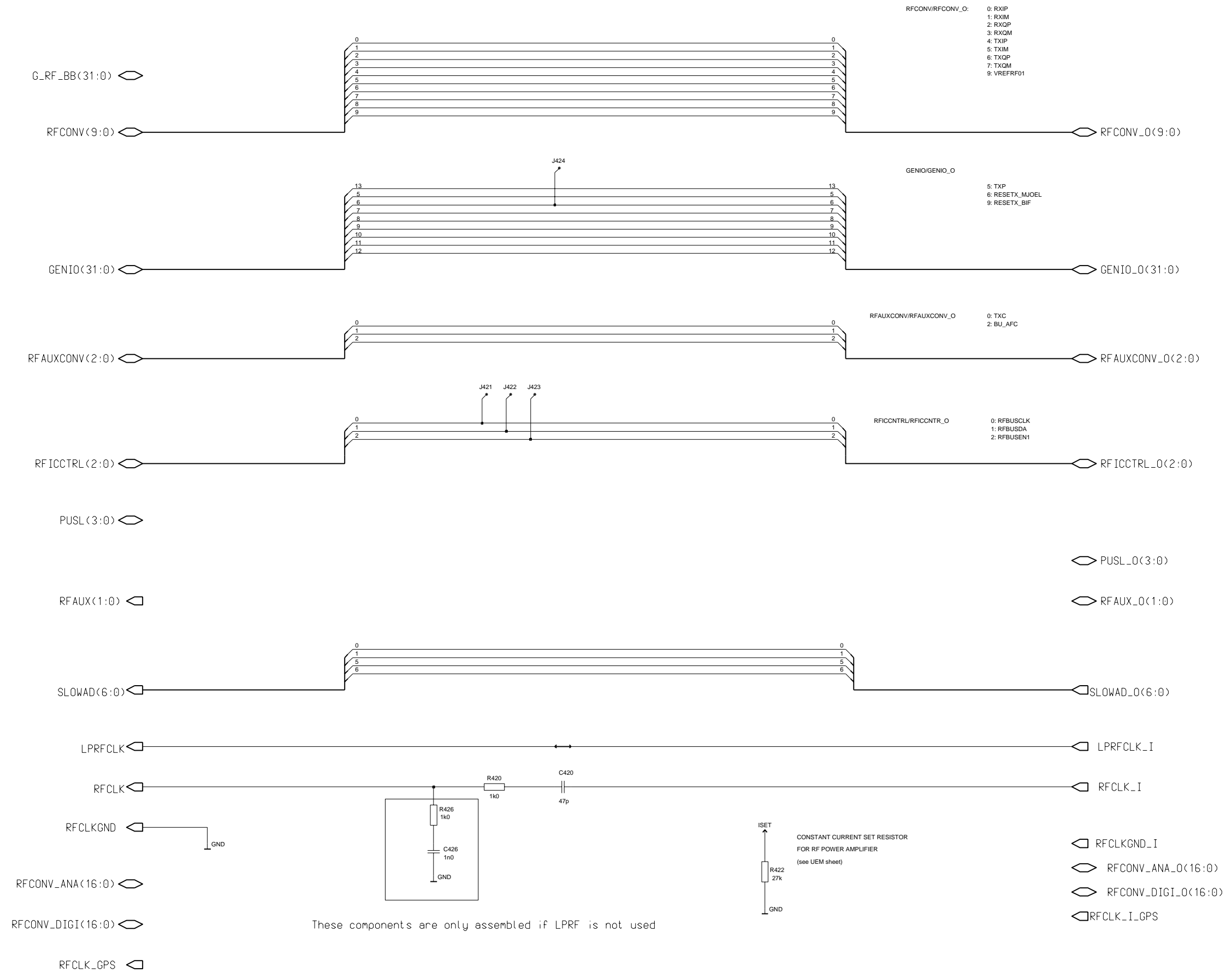

SIM v. 1.3 ed. 32

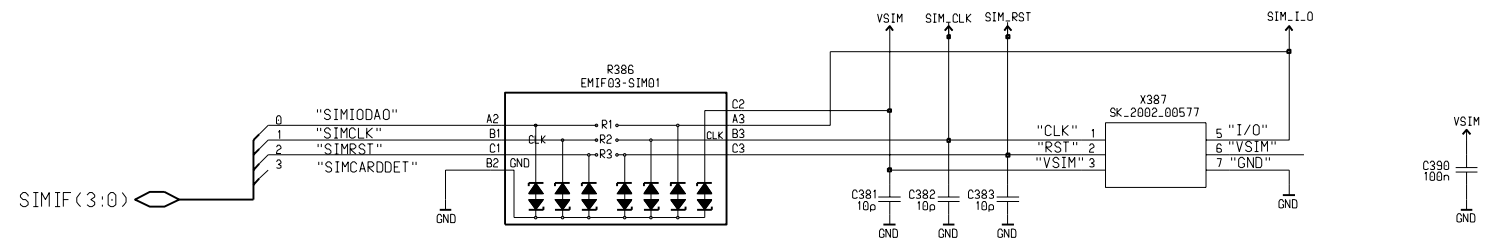

SIM2MMCIF(3:0)

GENIO(31:0)

G_SIM(7:0)

System connector v. 1.3 ed.51

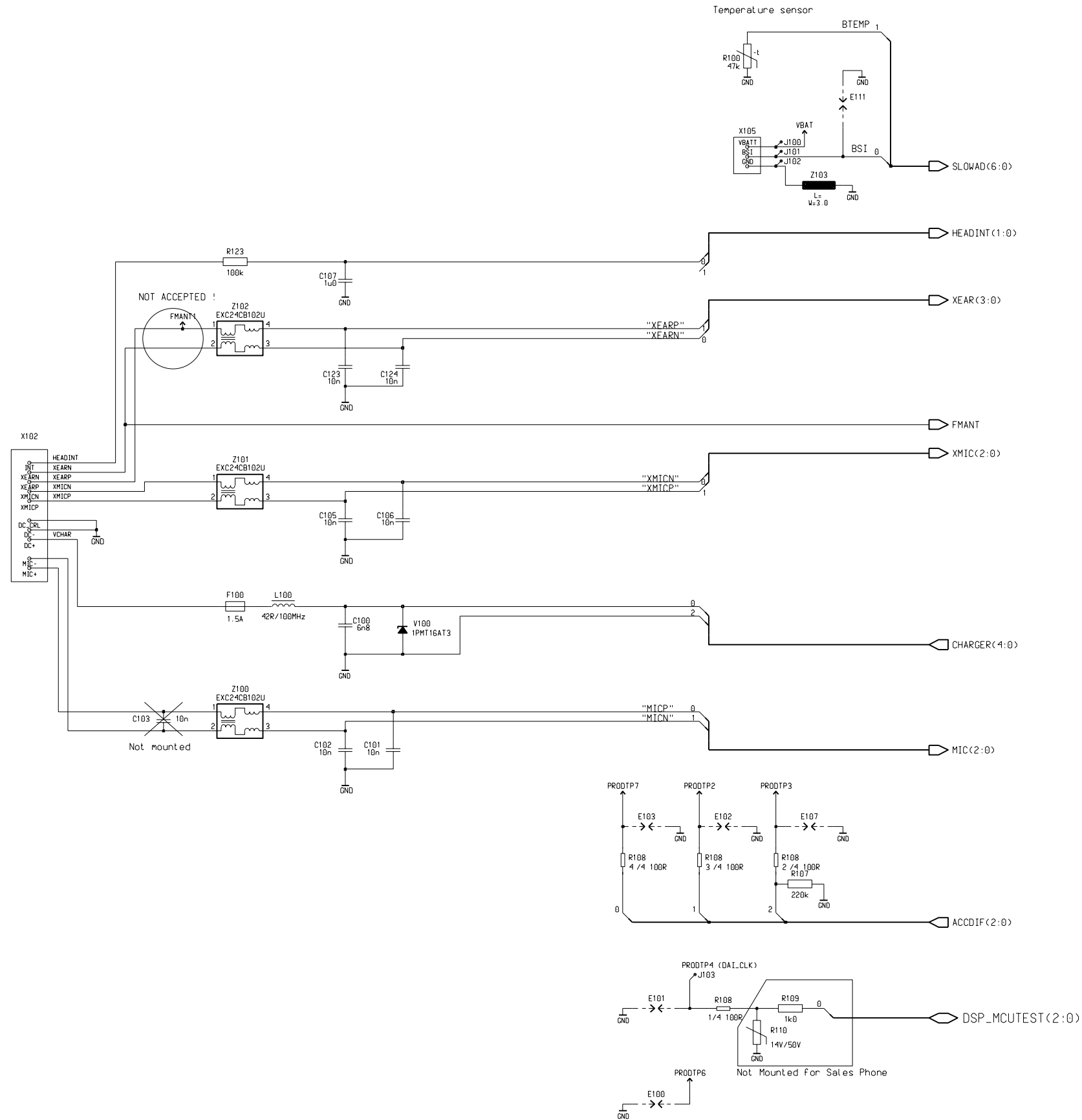

- ◁ UIDRV(5:0)
- ◁ IACCDIF(5:0)
- ◁ RFAUX(1:0)
- ▷ PWRONX
- ◁ SIMIF(3:0)
- ▷ HOOKINT
- ◁ USB_DIG(6:0)
- ◁ PUSL(3:0)
- ◁ AUDUEMCTRL(3:0)
- ◁ GENIO(31:0)
- ◁ GPIO(31:0)
- ▷ USB(2:0)
- ◁ APE_GPIO(15:0)
- ◁ G_SYS_CONN(11:0)
- ◁ IHF(1:0)

UPP 8M diagram, v. 2.0 ed. 107

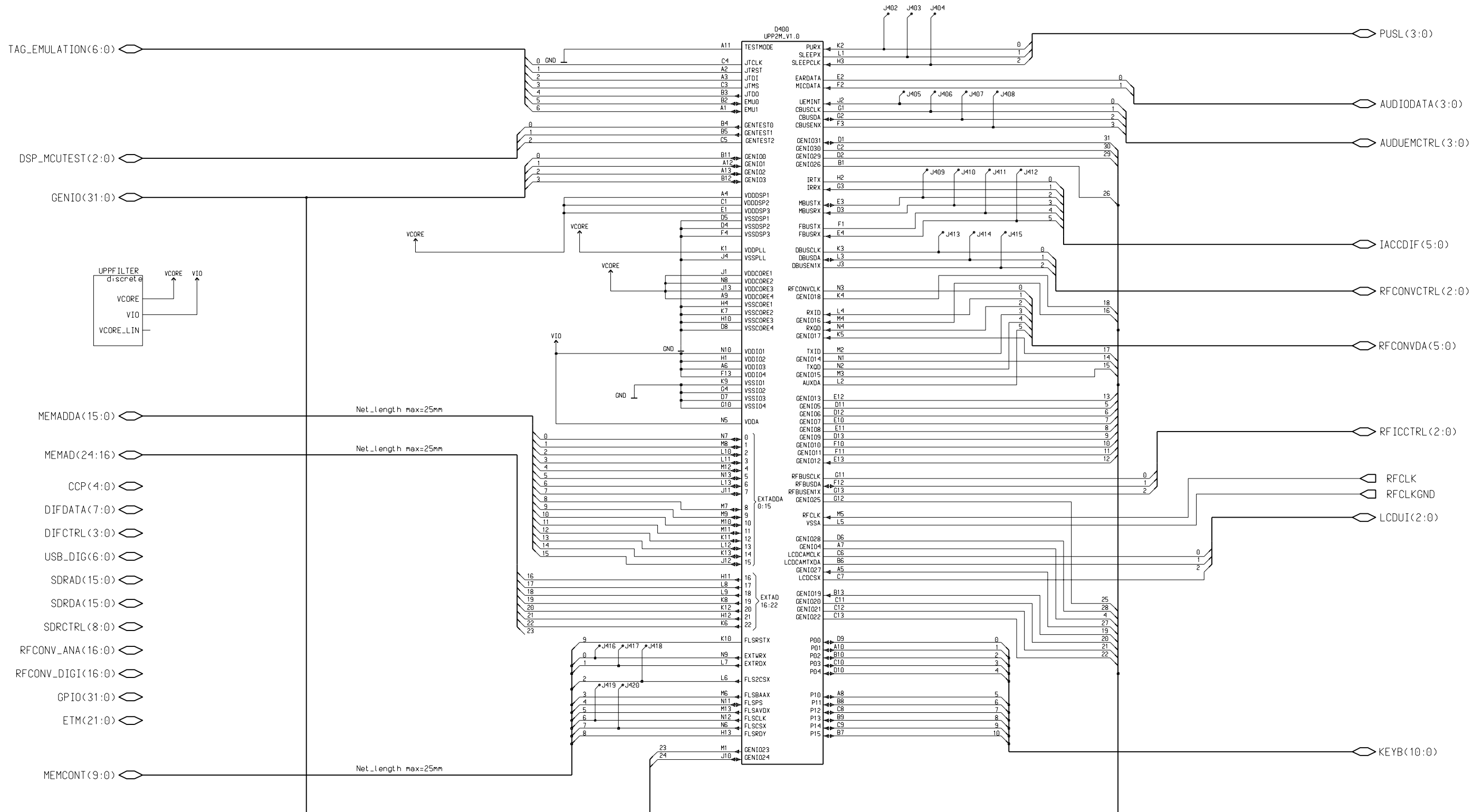

Discrete decoupling capacitors for UPP v. 1.3 ed.10

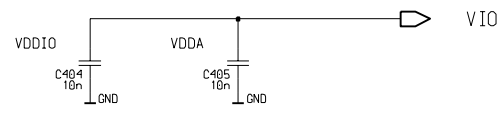
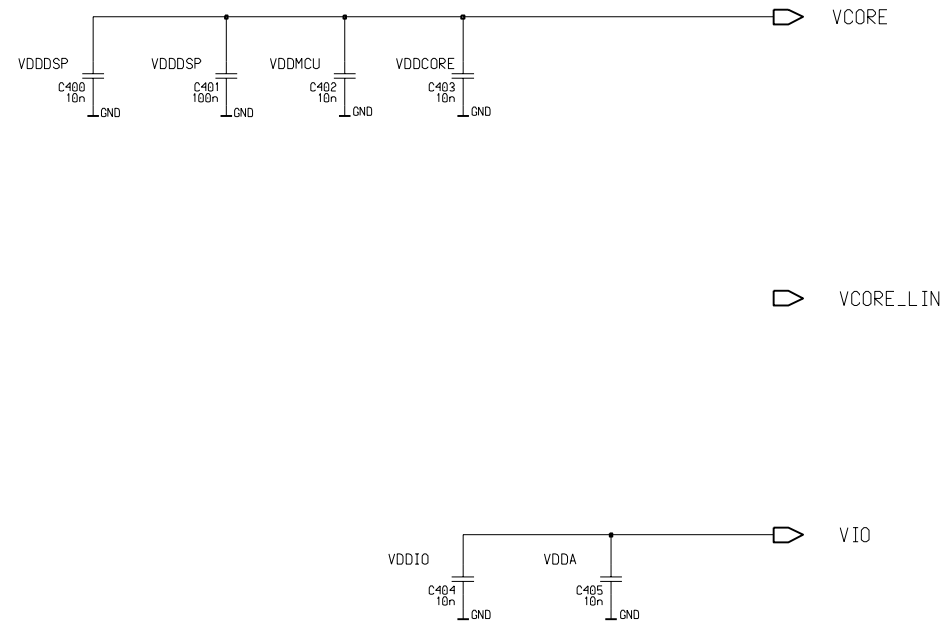

Audio and Global Ground v. 0.0 RH*

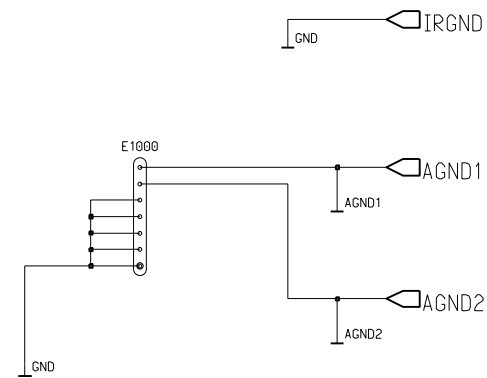

Component layout 1AW_07a, bottom side

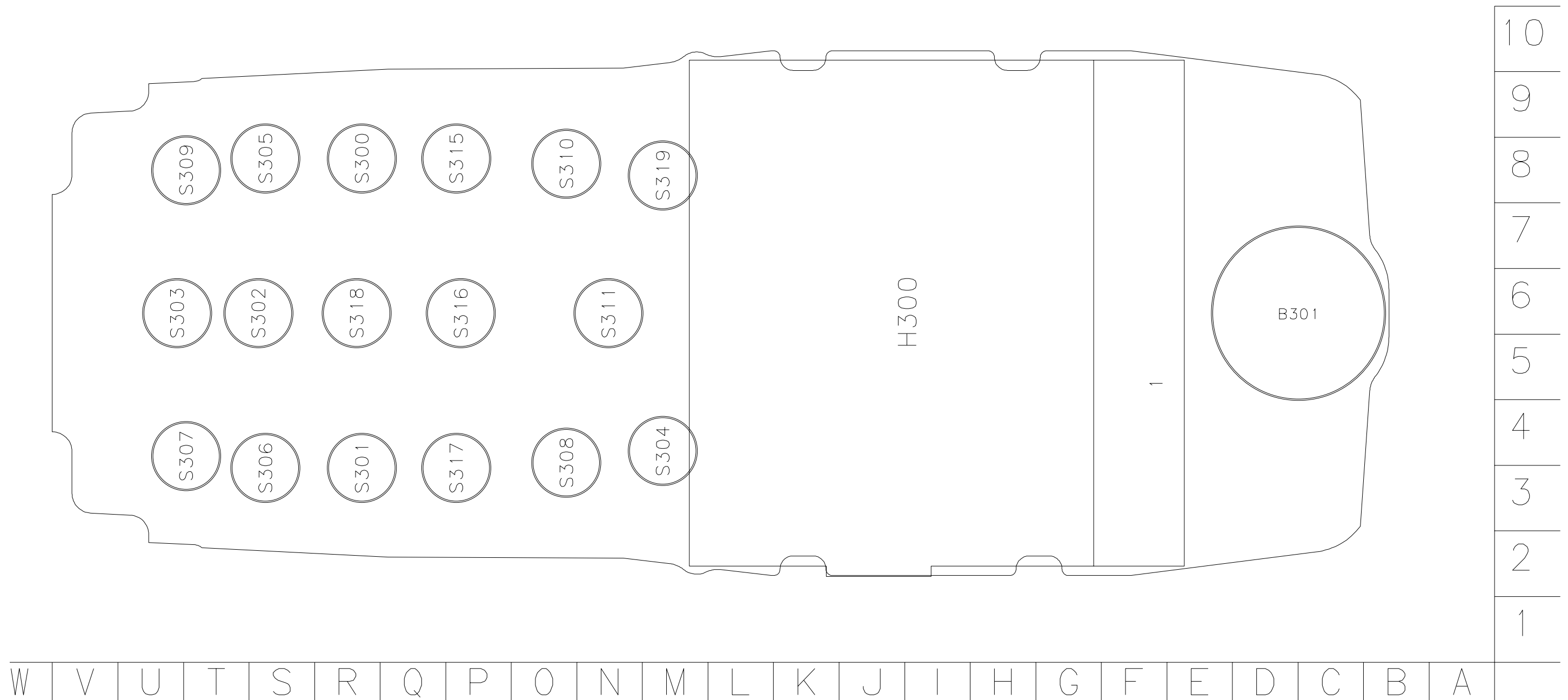

Test Points, Baseband

